

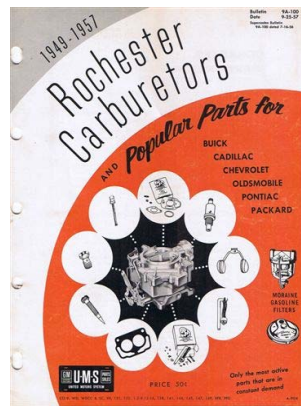

www.carburetor-manual.com

Would you like some Free Manuals?



<http://carburetor-manual.com/free-shop-manual-club-t-13.html>

Also visit <http://freeshopmanual.com> for more Free Manuals

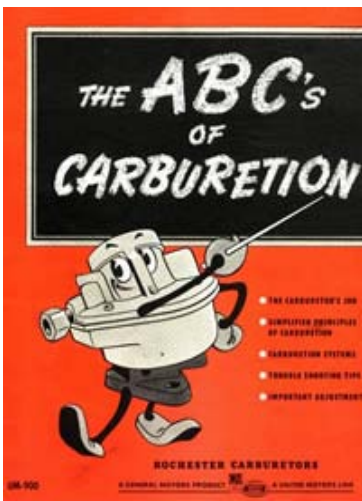

Also Visit my website for 7 FREE Download Manuals starting with this one.

"The ABC's of Carburetion"

[Click Here Now](#)

STROMBERG TOOLS



SER-350
MASTER TOOL KIT
 \$21.45 (Complete)

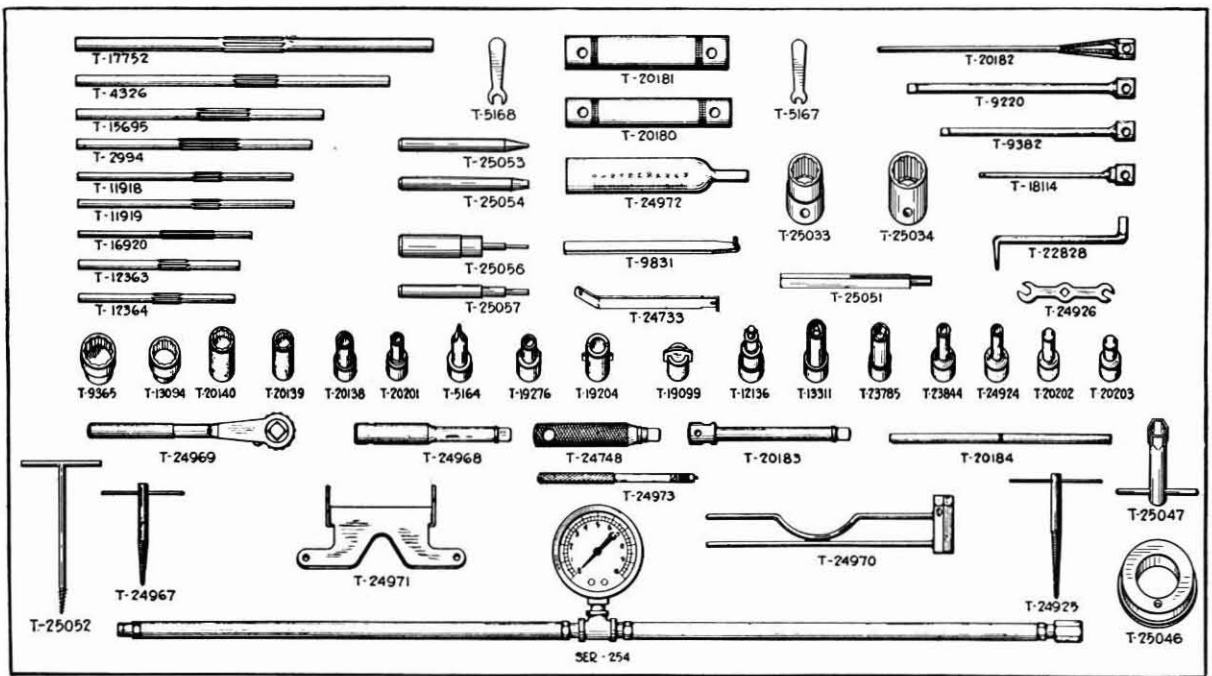

Tool No.	Tool Name	Net Price
T-2994	Line Reamer .3145"	\$ 9.25
T-4326	Line Reamer .378"	15.00
*T-5164	Screw Driver	1.00
T-5167	3/16" End Wrench	.25
T-5168	1/4" End Wrench	.25
T-9220	Screw Driver (Std.)	1.15
T-9365	13/16" Socket Wrench End (Std.)	.80
T-9382	Screw Driver (Std.)	1.15
T-9831	Idle Discharge Nozzle Knock Out Tool ("O" type Carbs.)	.75
T-11918	Line Reamer .2525"	6.00
T-11919	Line Reamer .254"	6.20
T-12136	Needle Valve Adjusting Wrench	1.30
T-12363	Line Reamer .375"	7.50
T-12364	Line Reamer .311"	6.00
T-13094	1 1/2" Socket Wrench End	.60
T-13311	Special Accelerating Wrench ("O" Type Carbs.)	2.40
T-15695	Line Reamer .379"	7.50
T-16920	Line Reamer .197"	5.00
T-17752	Line Reamer .502"	15.00
T-18114	Screw Driver (Std.)	1.15
*T-19099	Main Discharge Plug Screw Driver (E, AX and AA Type Carbs.)	1.15
*T-19204	Piston Sleeve Screw Driver ("D" Type Carbs.)	1.20
T-19276	Float Seat Wrench (DDR-5 Carb.)	1.10
*T-20138	3/8" By-Pass Jet Socket Wrench ("SF" Type Carbs.)	.85
*T-20139	1/2" Socket Wrench	.75
*T-20140	1 1/2" Socket Wrench	.80
T-20180	1 1/8" x 3/4" Socket Wrench	1.50
T-20181	1 1/8" x 7/8" Socket Wrench	1.50
T-20182	Bushing Remover	3.30
T-20183	Extension Bar	1.25
T-20184	Socket Handle	.50
*T-20201	Economizer Needle Valve Socket Wrench ("D" and "U" Type Carbs.)	1.15

Tool No.	Tool Name	Net Price
T-20202	Main Discharge Jet Nut Screw Driver ("U-2" Carbs.)	\$ 1.15
T-20203	Main Discharge Jet Nut Screw Driver ("UU-2" Carbs.)	1.15
*T-22828	Offset Screw Driver	.45
*T-23785	Check Valve Wrench (P-16990)	.80
*T-23844	Metering Jet Wrench (P-17004)	.95
*T-24733	Vacuum Economizer—Float Adjustment Wrench ("U" and "E" Type Carbs.)	.55
T-24748	Screw Driver Handle	.60
*T-24924	Metering Jet Wrench (P-19442—P-22660)	1.10
*T-24925	Main Jet Remover ("E" Type Carbs.)	1.15
T-24926	3/8" x 1/2" End Wrench	.15
*T-24967	Main Jet Remover ("AA" Type Carbs.)	1.00
*T-24968	Grip Handle	1.45
*T-24969	Ratchet Assembly	1.30
*T-24970	By-Pass Jet—Check Valve Tester	.70
*T-24971	Float Level Gauge ("AA" Type Carbs.)	1.15
T-24972	Burette Gauge (Checking Fuel Pump Capacity)	1.65
T-24973	Screw Starter (For Removing By-Pass Jets, Check Valves, etc.)	1.00
T-25033	3/16" Socket Wrench End Std.	.80
T-25034	5/16" Socket Wrench End Std.	.80
*T-25046	Choke Setting Gauge	.75
*T-25047	3/16" Socket Wrench for Automatic Choke	.50
*T-25051	Pump Wedge Driver	.50
*T-25052	Lead Ball Plug Remover	.50
*T-25053	.125" Lead Ball Set	.40
*T-25054	.180" Lead Ball Set	.40
*T-25056	.101", .172", .546" Gauge—Choke Valve Setting	.50
*T-25057	.172", .250", .312" Gauge—Choke Valve Setting	.50
Ser-254	Fuel Pressure Gauge	3.50
Ser-350	Tool Cabinet and Tools	21.45

*Tools included in Stromberg Tool Cabinet—Ser-350.

CAR DEALERS' TOOL KITS

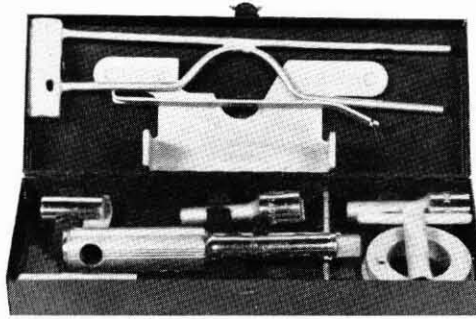

CAR DEALERS' KIT

The CAR DEALERS' TOOL KITS consist only of the special tools that are required to service the STROMBERG CARBURETORS used as standard equipment on the cars listed. Illustrated above is a typical car dealer's kit.

The metal container is of heavy gauge steel and is of convenient size. Individual tools can be purchased if desired, to bring previous tool kits up to date.

Cadillac-LaSalle Tool Kit No. SER-361 \$10.80 (Complete) Contents of Kit

Tool No.	Tool Name	Net Price
T-19099	Main Jet Plug Screw Driver	\$ 1.15
T-23844	Metering Jet Socket Wrench	.95
T-24924	Metering Jet Socket Wrench	1.10
T-24733	Power Piston and Float Bender Tool	.55
T-24967	Main Discharge Jet Remover	1.00
T-24970	By-Pass Jet and Check Valve Tester	.70
T-24971	Float Gauge	1.15
T-24968	Grip Handle	1.45
T-25046	Choke Gauge	.75
T-25047	Choke Stem Nut Socket Wrench	.50
T-25056	Choke Valve Step Gauge	.50
Ser-360	Kit	1.00

Buick Tool Kit No. SER-373 \$10.80 (Complete) Contents of Kit

Tool No.	Tool Name	Net Price
T-24924	Main Metering Jet Wrench	\$ 1.10
T-24968	Grip Handle	1.45
T-24967	Main Discharge Jet Remover	1.00
T-24733	Vacuum Power Piston and Float Bender Tool	.55
T-24970	By-Pass Jet and Check Valve Tester	.70
T-24971	Float Gauge ("AA" Carbs.)	1.15
T-19099	Main Jet Plug Screw Driver	1.15
T-25046	Choke Gauge	.75
T-25047	Socket Wrench	.50
T-23844	Main Metering Jet Wrench	.95
T-25057	Choke Valve Step Gauge	.50
Ser-360	Kit	1.00

Nash Tool Kit No. SER-385 \$7.90 (Complete) Contents of Kit

Tool No.	Tool Name	Net Price
T-24970	By-Pass Jet and Check Valve Tester	\$.70
T-24733	Power Piston and Float Bender Tool	.55
T-19099	Main Jet Plug Screw Driver	1.15
T-23844	Metering Jet Socket Wrench	.95
T-24924	Metering Jet Socket Wrench	1.10
T-24967	Main Discharge Jet Remover	1.00
T-24968	Handle	1.45
Ser-360	Kit	1.00

Dodge Tool Kit No. SER-375 \$7.90 (Complete) Contents of Kit

Tool No.	Tool Name	Net Price
T-24970	By-Pass Jet and Check Valve Tester	\$.70
T-24733	Power Piston and Float Bender Tool	.55
T-19099	Main Jet Plug Screw Driver	1.15
T-23844	Metering Jet Socket Wrench	.95
T-24924	Metering Jet Socket Wrench	1.10
T-24967	Main Discharge Jet Remover	1.00
T-24968	Handle	1.45
Ser-360	Kit	1.00

Studebaker Tool Kit No. SER-386 \$9.55 (Complete) Contents of Kit

Tool No.	Tool Name	Net Price
T-24970	By-Pass Jet and Check Valve Tester	\$.70
T-24733	Power Piston and Float Bender Tool	.55
T-19099	Main Jet Plug Screw Driver	1.15
T-23844	Metering Jet Socket Wrench	.95
T-24924	Metering Jet Socket Wrench	1.10
T-24967	Main Discharge Jet Remover	1.00
T-24968	Grip Handle	1.45
T-24971	Float Gauge	1.15
T-25047	Choke Stem Nut Socket Wrench	.50
Ser-360	Kit	1.00

Packard Tool Kit No. SER-376 \$11.35 (Complete) Contents of Kit

Tool No.	Tool Name	Net Price
T-24970	By-Pass Jet and Check Valve Tester	\$.70
T-24733	Power Piston and Float Bender Tool	.55
T-19099	Main Jet Plug Screw Driver	1.15
T-23785	Check Valve Socket Wrench	.80
T-20138	By-Pass Jet Socket Wrench	.85
T-24967	Main Discharge Jet Remover	1.00
T-24968	Grip Handle	1.45
T-25047	Choke Stem Nut Socket Wrench	.50
T-25056	Choke Valve Step Gauge	.50
T-23844	Metering Jet Wrench	.95
T-24924	Metering Jet Wrench	1.10
T-20140	Float Needle Valve Seat Socket Wrench	.80
Ser-360	Kit	1.00

Chrysler Tool Kit No. SER-387 \$11.50 (Complete) Contents of Kit

Tool No.	Tool Name	Net Price
T-19099	Main Discharge Plug Screw Driver	\$ 1.15
T-23844	Metering Jet Wrench	.95
T-24924	Metering Jet Wrench	1.10
T-24733	Vacuum Power Piston and Float Adjusting Tool	.55
T-24967	Main Discharge Jet Remover	1.00
T-24970	By-Pass Jet and Check Valve Tester	.70
T-24971	Float Level Gauge (AA Carbs.)	1.15
T-24968	Grip Handle	1.45
T-23785	Check Valve Socket Wrench	.80
T-20138	By-Pass Jet Socket Wrench	.85
T-20140	Float N. V. Seat Socket Wrench	.80
Ser-360	Kit	1.00

White Tool Kit No. SER-388 \$12.30 (Complete) Contents of Kit

Tool No.	Tool Name	Net Price
T-19099	Main Discharge Plug Screw Driver	\$ 1.15
T-23844	Metering Jet Wrench	.95
T-24924	Metering Jet Wrench	1.10
T-24733	Vacuum Piston and Float Bender Tool	.55
T-24967	Main Discharge Jet Remover	1.00
T-24968	Grip Handle	1.45
T-24970	By-Pass Jet and Check Valve Tester	.70
T-24971	Float Gauge	1.15
T-23785	Check Valve Socket Wrench	.80
T-20138	By-Pass Jet Socket Wrench	.85
T-20140	Float N. V. Seat Socket Wrench	.80
T-25034	Float N. V. Seat Socket Wrench	.80
Ser-360	Kit	1.00

BENDIX PRODUCTS DIVISION OF BENDIX AVIATION CORPORATION

401 BENDIX DRIVE

SOUTH BEND, IND., U. S. A.